

TYPICAL ELEVATION WITH FASTENER SPACING

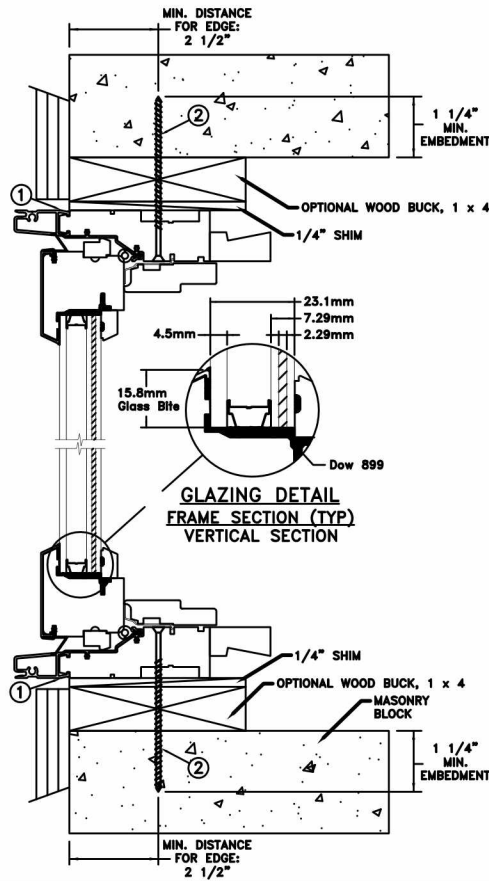

THROUGH FRAME INSTALLATION

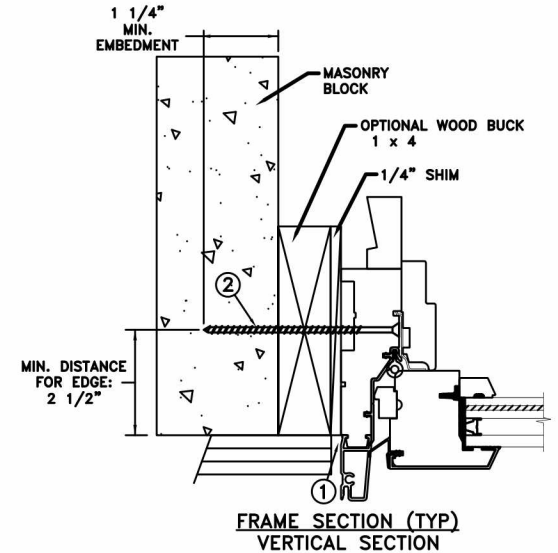

Max Frame	DP	IMPACT
60" X 60"	+50/-65	YES

Installation Notes:

1. Seal flange/frame to substrate.
2. Use 3/16" Tapcon or equivalent fasteners through frame with sufficient length to penetrate a minimum of 1 1/4" into concrete or masonry at each location with a 2 1/2" min. from edge distance. For concrete (min. fc = 3000 psi) or masonry substrate (CMU shall adhere to ASTM C90).
3. Host structure (wood buck, masonry, steel) to be designed and anchored to properly transfer all loads to the structure. The host structure is the responsibility of the architect or engineer of record for the project of installation.

General Notes:

1. The product shown herein is designed, tested and manufactured to comply with the wind load criteria of the adopted International Building Code (IBC), the International Residential Code (IRC), the Florida Building Code (FBC) and the industry standard requirement for the stated conditions.
2. Buck, framing and masonry by others and is responsibility of architect or engineer of record.
3. All glazing shall conform to ASTM E1300.
4. At minimum, glazing shall be 4.5mm annealed - 11.4mm airspace - 2.5mm annealed - 2.2mm PVB Interlayer by Dupont - 2.5mm annealed insulating glass.

Digitally signed by Hermes F. Norero, P.E.
Reason: I am approving this document
Date: 2016.06.16 12:19:56 -0400

This schedule addresses only the fasteners required to anchor the window to achieve the rated design pressure up to the size limitations noted. It is not intended as a guide to the installation process and does not address the sealing consideration that may arise in different wall conditions. For the complete installation procedure, see the instructions packaged with the window or go to www.jeld-wen.com.

DISCLAIMER:

This drawing and its contents are confidential and are not to be reproduced or copied in whole or in part or used or disclosed to others except as authorized by JELD-WEN Inc.

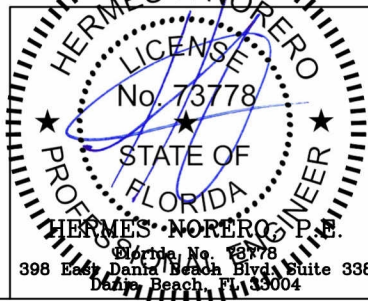

PROJECT ENGINEER:	DATE:	JELD-WEN	3737 LAKEPORT BLVD. KLAMATH FALLS OR, 97601 PHONE: (800) 535-3936	
DRAWN BY: D. Vezo	SCALE: NTS			
CHECKED BY: ----	TITLE:	Siteline Clad Casement Fixed Window		
APPROVED BY: ----				
PART/PROJECT No.: D009404				
IDENTIFIER No. SJW2015-117	PLANT NAME AND LOCATION: ----	CAD DWG. No.:	REV: 00	SHEET 1 of 4

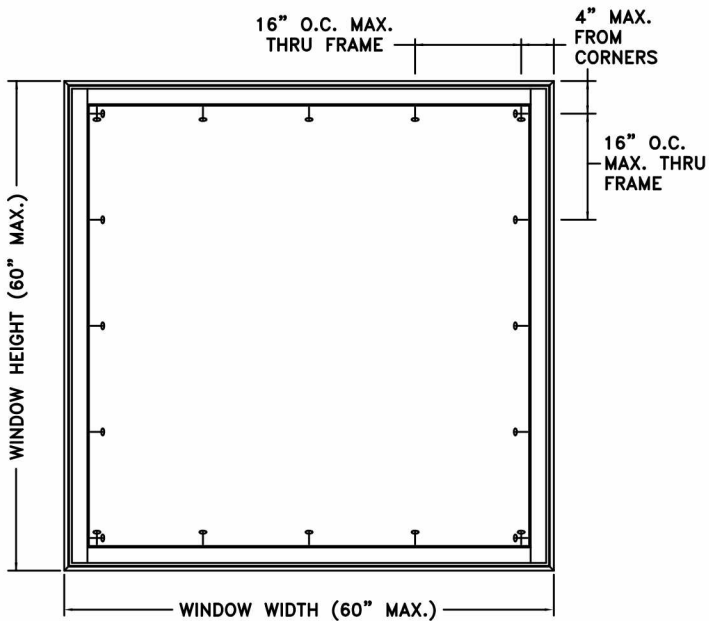

TYPICAL ELEVATION WITH FASTENER SPACING

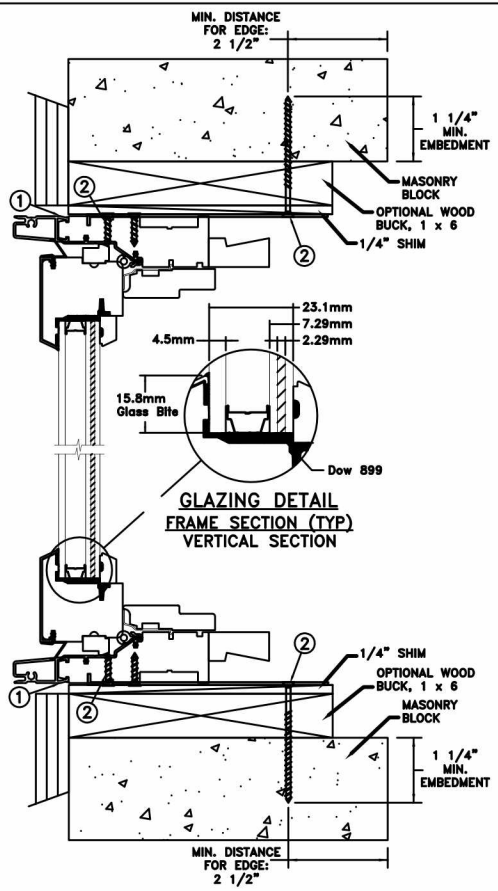

GLAZING DETAIL
FRAME SECTION (TYP)
VERTICAL SECTION

MASONRY STRAP
INSTALLATION

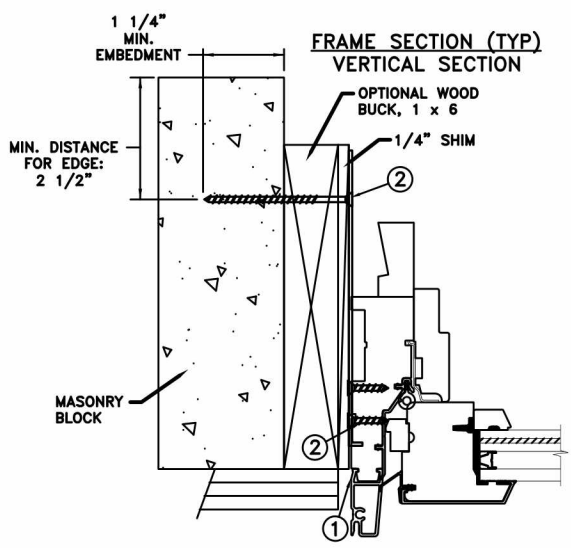

FRAME SECTION (TYP)
VERTICAL SECTION

Max Frame 60" X 60"	DP +50/-65	IMPACT YES
------------------------	---------------	---------------

Installation Notes:

1. Seal flange/frame to substrate.
2. Use 3/16" Tapcon or equivalent fasteners through strap with sufficient length to penetrate a minimum of 1 1/4" into concrete or masonry at each location with a 2 1/2" min. from edge distance. 2-#8 x 1/2" PH screws through the strap into frame. For concrete (min. fc = 3000 psi) or masonry substrate (CMU shall adhere to ASTM C90).
3. Host structure (wood buck, masonry, steel) to be designed and anchored to properly transfer all loads to the structure. The host structure is the responsibility of the architect or engineer of record for the project of installation.

General Notes:

1. The product shown herein is designed, tested and manufactured to comply with the wind load criteria of the adopted International Building Code (IBC), the International Residential Code (IRC), the Florida Building Code (FBC) and the industry standard requirement for the stated conditions.
2. Buck, framing and masonry by others and is responsibility of architect or engineer of record.
3. All glazing shall conform to ASTM E1300.
4. At minimum, glazing shall be 4.5mm annealed - 11.4mm airspace - 2.5mm annealed - 2.2mm PVB Interlayer by Dupont - 2.5mm annealed insulating glass.

This schedule addresses only the fasteners required to anchor the window to achieve the rated design pressure up to the size limitations noted. It is not intended as a guide to the installation process and does not address the sealing consideration that may arise in different wall conditions. For the complete installation procedure, see the instructions packaged with the window or go to www.jeld-wen.com.

DISCLAIMER:

This drawing and its contents are confidential and are not to be reproduced or copied in whole or in part or used or disclosed to others except as authorized by JELD-WEN Inc.

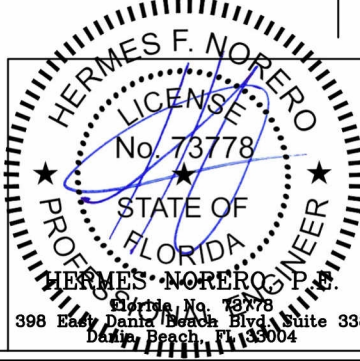

PROJECT ENGINEER:	DATE:	3737 LAKEPORT BLVD.	
DRAWN BY:	SCALE:	KLAMATH FALLS OR, 97601	
CHECKED BY:	TITLE:	PHONE: (541) 882-3451	
APPROVED BY:	Siteline Clad Casement Fixed Window		
PART/PROJECT No.:			
IDENTIFIER No.:	PLANT NAME AND LOCATION:	CAD DWG. No.:	REV: 00 SHEET 2 of 4

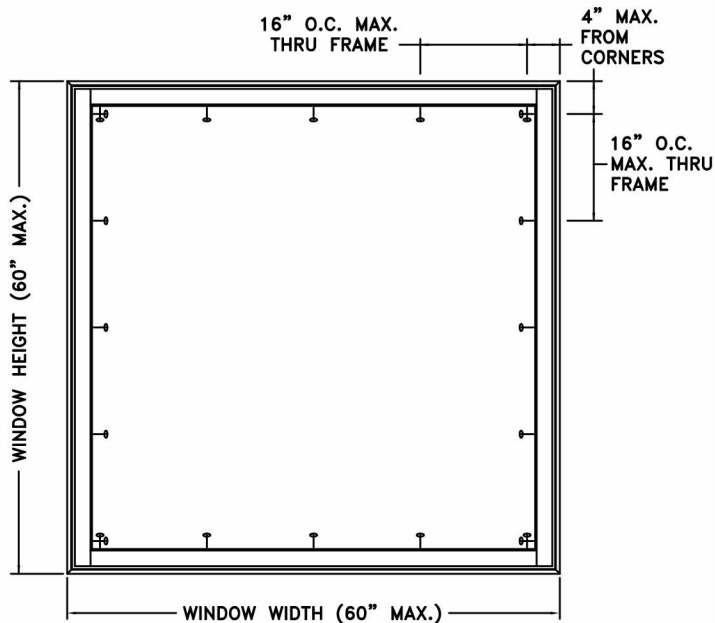

TYPICAL ELEVATION WITH FASTENER SPACING

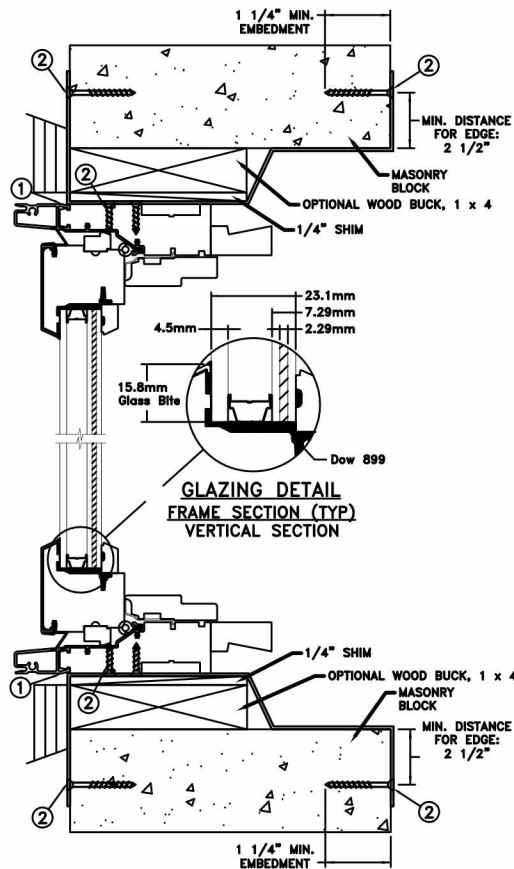

MASONRY STRAP INSTALLATION

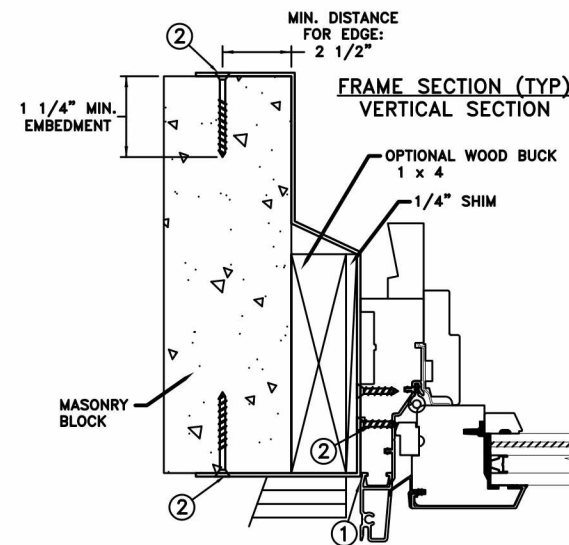

Max Frame	DP	IMPACT
60" X 60"	+50/-65	YES

Installation Notes:

1. Seal flange/frame to substrate.
2. Use 3/16" Tapcon or equivalent fasteners through the interior and exterior of the strap with sufficient length to penetrate a minimum of 1 1/4" into concrete or masonry at each location with a 2 1/2" min. from edge distance. 2-#8 x 1/2" PH screws through the strap into frame. For concrete (min. fc = 3000 psi) or masonry substrate (CMU shall adhere to ASTM C90).
3. Host structure (wood buck, masonry, steel) to be designed and anchored to properly transfer all loads to the structure. The host structure is the responsibility of the architect or engineer of record for the project of installation.

General Notes:

1. The product shown herein is designed, tested and manufactured to comply with the wind load criteria of the adopted International Building Code (IBC), the International Residential Code (IRC), the Florida Building Code (FBC) and the industry standard requirement for the stated conditions.
2. Buck, framing and masonry by others and is responsibility of architect or engineer of record.
3. All glazing shall conform to ASTM E1300.
4. At minimum, glazing shall be 4.5mm annealed - 11.4mm airspace - 2.5mm annealed - 2.2mm PVB Interlayer by Dupont - 2.5mm annealed insulating glass.

This schedule addresses only the fasteners required to anchor the window to achieve the rated design pressure up to the size limitations noted. It is not intended as a guide to the installation process and does not address the sealing consideration that may arise in different wall conditions. For the complete installation procedure, see the instructions packaged with the window or go to www.jeld-wen.com.

DISCLAIMER:

This drawing and its contents are confidential and are not to be reproduced or copied in whole or in part or used or disclosed to others except as authorized by JELD-WEN Inc.

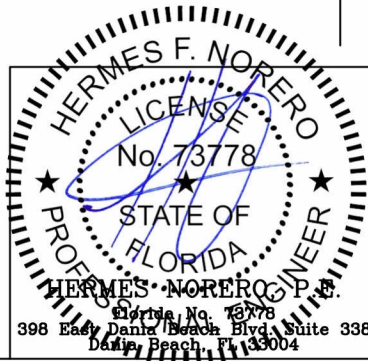

PROJECT ENGINEER:	DATE:	JELD-WEN	3737 LAKEPORT BLVD. KLAMATH FALLS OR, 97601 PHONE: (541) 882-3451
DRAWN BY: D. Vezo	SCALE: NTS		
CHECKED BY: ----	TITLE:	Siteline Clad Casement Fixed Window	
APPROVED BY: ----	PART/PROJECT No.:		
IDENTIFIER No.:	PLANT NAME AND LOCATION:	CAD DWG. No.:	REV: 00
SJW2015-117	----	----	SHEET 3 of 4

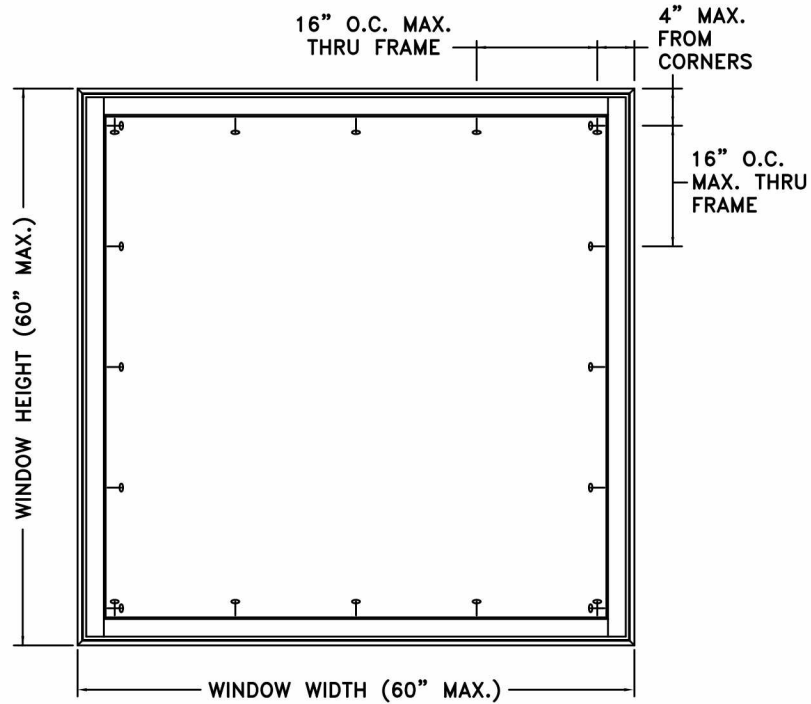

TYPICAL ELEVATION WITH FASTENER SPACING

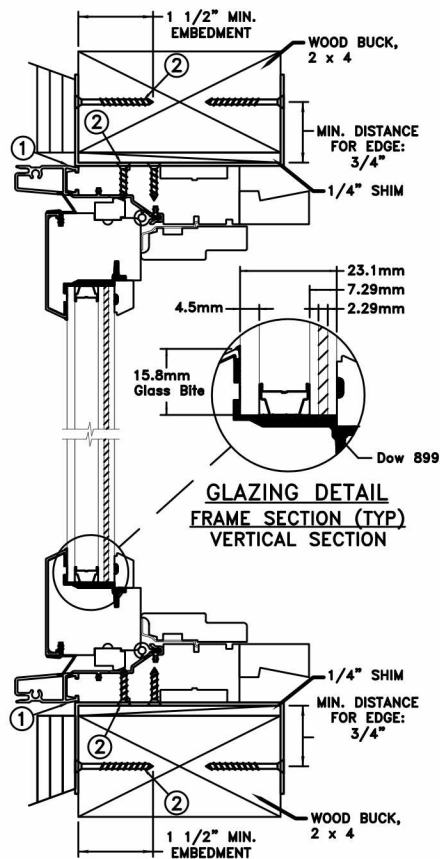

MASONRY STRAP
INSTALLATION

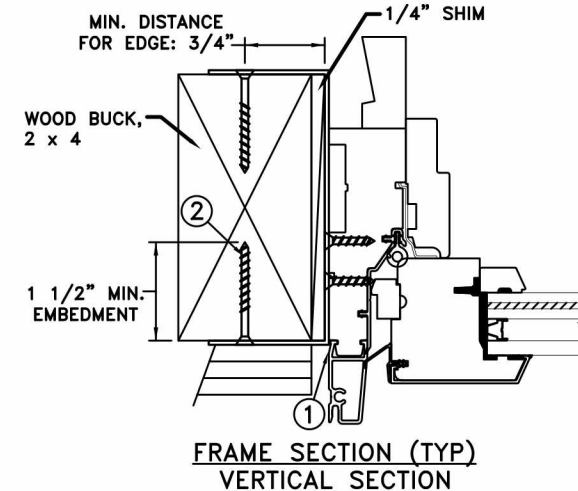

Max Frame	DP	IMPACT
60" X 60"	+50/-65	YES

Installed Fastener Schedule:

1. Seal flange/frame to substrate.
2. Install masonry straps to wood frame using #8 corrosion resistant fasteners no more than 4" from each corner and 17" o.c. along the head and 20" o.c. along the jambs. Bend straps around buck to the interior and exterior, and secure with #8 fastener thru masonry strap into buck. Fasteners must be long enough to penetrate at least 1 1/2" into framing members. Minimum specific gravity = (Min. S.G. = 0.42).
3. Host structure (wood buck, stud framing and opening) to be designed and anchored to properly transfer all loads to the structure. The host structure is the responsibility of the architect or engineer of record for the project of installation.

This schedule addresses only the fasteners required to anchor the window to achieve the rated design pressure up to the size limitations noted. It is not intended as a guide to the installation process and does not address the sealing consideration that may arise in different wall conditions. For the complete installation procedure, see the instructions packaged with the window or go to www.jeld-wen.com.

DISCLAIMER:

This drawing and its contents are confidential and are not to be reproduced or copied in whole or in part or used or disclosed to others except as authorized by JELD-WEN Inc.

General Notes:

1. The product shown herein is designed, tested and manufactured to comply with the wind load criteria of the adopted International Building Code (IBC), the International Residential Code (IRC), the Florida Building Code (FBC) and the industry standard requirement for the stated conditions.
2. Buck, framing and masonry by others and is responsibility of architect or engineer of record.
3. All glazing shall conform to ASTM E1300.
4. At minimum, glazing shall be 6.0mm annealed - 9.0mm airspace - 4.0mm annealed - 2.29mm SGP Interlayer by Dupont - 4.0mm annealed insulating glass.

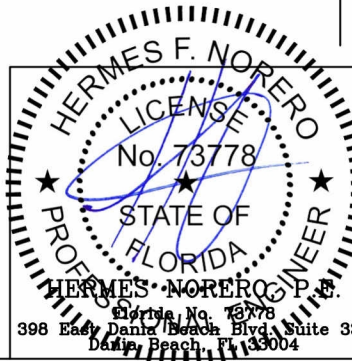

PROJECT ENGINEER:	DATE:	JELD-WEN	3737 LAKEPORT BLVD.	
DRAWN BY: D. Vezo	06/06/2016 SCALE: NTS		KLAMATH FALLS OR, 97601 PHONE: (800) 535-3936	
CHECKED BY: ----	TITLE:	Siteline Clad Casement Fixed Window		
APPROVED BY: ----	PART/PROJECT No.:			
IDENTIFIER No.:	PLANT NAME AND LOCATION:	CAD DWG. No.:	REV: 00	SHEET 4 of 4